

F-SL500

ELECTRIC MAGNETIC SHEAR LOCK



Product Features

- Ideal for Swing-In & Swing-Out Doors
- Dual Voltage Selectable (12VDC / 24VDC)
- Low Current Consumption
- Reliable Holding Force
- Hall Effect Sensor Monitoring Output
- Durable & Silence Operation
- Cosmeticize Anodized Aluminum Bracket
- Surge & Spike Protection PCB
- Full Range of Optional Brackets
- Anti-Residual Magnetism Kick Off Button

Technical Specifications

Model	F-SL500
Power Supply	DC 12V ~ DC24V ±15%
Operation Current	900mA
Standby Current	220mA@12VDC mA ±5% 190mA@24VDC mA ±5%
Application	All types of 90 ° ~ 180 ° door (aluminium or wooden doors)
Maximum Shear Force	2600Ibs (1200kg)
Magnetic Distance(Max.)	3mm @12V / 5mm @24V
Operation Delay Time	0.5~25 Sec.(Available to set)
Lock Status Sensor	NC. & N.O. Output (1A@30VDC)
Relock Function	Maximum 60 times
Demagnetizer Design	Instant demagnetizer when power is off.
Indicator	Double-colored LED light
Dimensions body	182mm(L) x 30mm(W) x 25mm(D)
Dimensions armature	182mm(L) x 30mm(W) x 23.6mm(D)
Weight	1200g

Dimension:

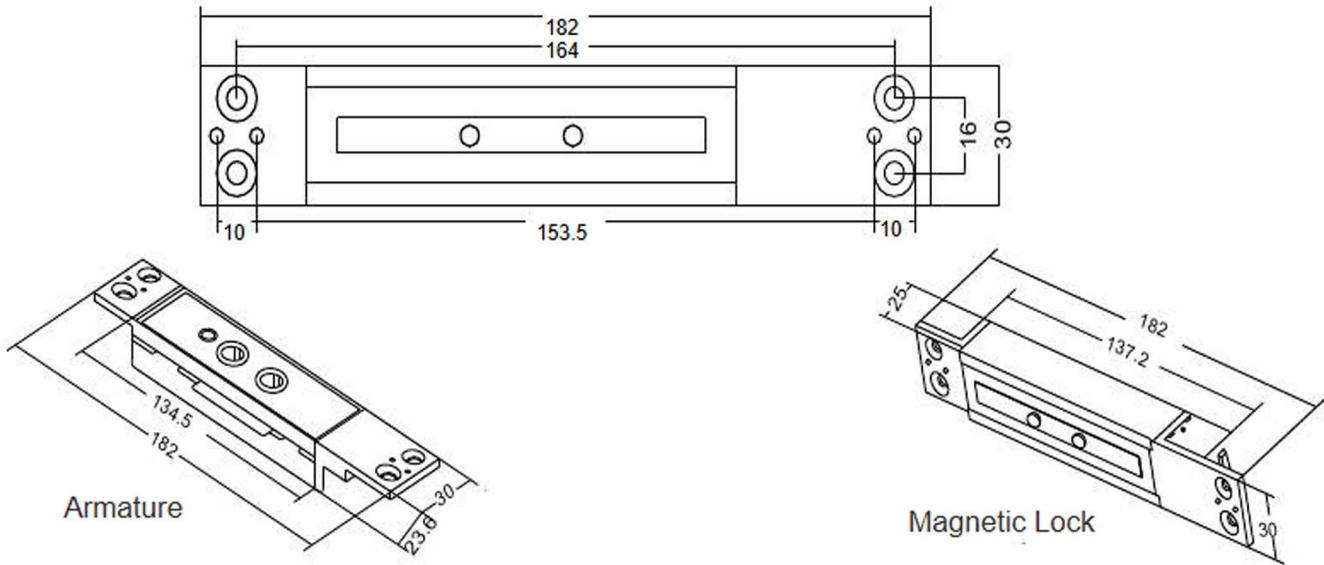

Connection Details:

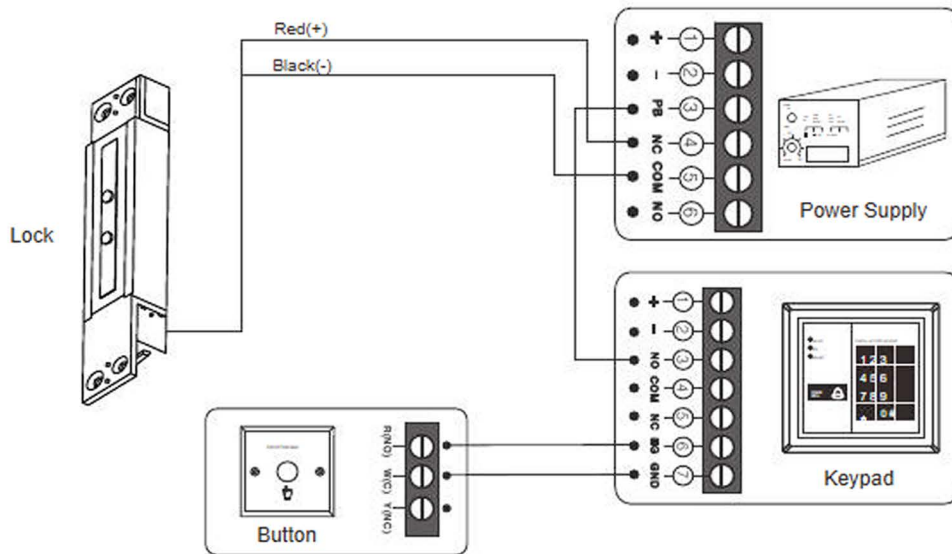

Model Color	9 PIN Connection		
Red	DC 12V	Black	GND
Purple	Purple wire of the light	Orange	Orange wire of the light
Green	Door Positions Sensor NO	※	Dangling
Brown	Lock Positions Sensor NC	Blue	Lock Status Sensor NO
Gary	Lock Positions Sensor COM	White	Door Status Sensor COM
Delay Time	0S	5S	10S
			15S